

Modular Cooking Range Line 700XP 4 Drawer Refrigerated Base

ITEM # _____

MODEL # _____

NAME # _____

SIS # _____

AIA # _____

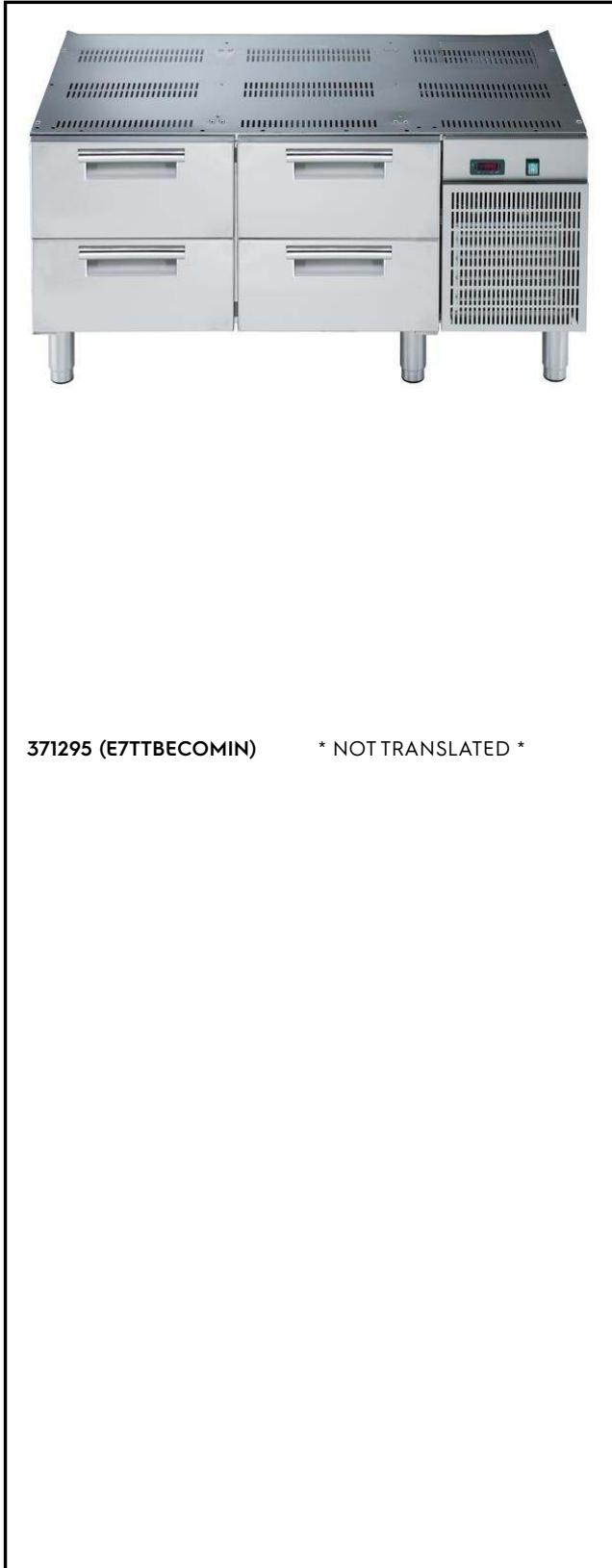

371295 (E7TTBECOMIN)

* NOT TRANSLATED *

Main Features

- Unit can be easily installed below other 700 line top models.
- Adjustable temperature range from -2 °C to +10 °C to suit meat, fish and dairy storage requirements.
- Forced air circulation for rapid cooling and an even temperature distribution.
- Right angled side edges eliminate gaps and possible dirt traps between units.
- Defrosting and automatic evaporation of condense drain: the condense is automatically evaporated thanks to the electric resistance in the condense drain container.
- GN compliant.
- Designed for modular installation into the cooking block.

Construction

- Exterior panels in Stainless steel with Scotch Brite finish to meet the highest hygiene standards.
- Built-in compressor to suit operating conditions.
- Access to all components from the front.
- Unit delivered with 150 mm height adjustable feet in Stainless steel. Feet can be extended up to 250 mm.

Sustainability



- CFC and HCFC free (highly ecological refrigerant type: R290).

Optional Accessories

- GN2/1 chrome grid for static oven PNC 164250
- Flanged feet kit PNC 206136
- Frontal kicking strip for concrete installation, 1200mm PNC 206151
- Frontal kicking strip, 1200mm (not for refr-freezer base) PNC 206178
- 4 feet for concrete installation PNC 206210
- 2 panels for service duct for single "top on base" installation PNC 206248
- Pair of side kicking strips PNC 206249
- Pair of side kicking strips for concrete installation PNC 206265
- 2 DRAWERS FOR REFRIGERATED BASE 700 LINE PNC 206351
- Base support for feet or wheels - 1200mm (700/900) PNC 206368
- Base support for feet or wheels - 1600mm (700/900) PNC 206369
- Rear paneling - 1200mm (700/900) PNC 206376
- KIT 6 WHEELS - 3SWIVELLING WITH BRAKE-UK PNC 206432
- 2 side covering panels, h=700mm, d=700mm PNC 216000

APPROVAL: _____

Front

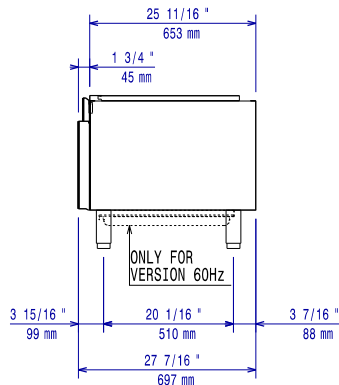

Side

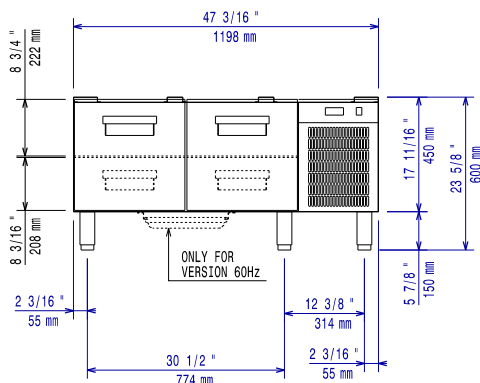

EI = Electrical inlet (power)

Top

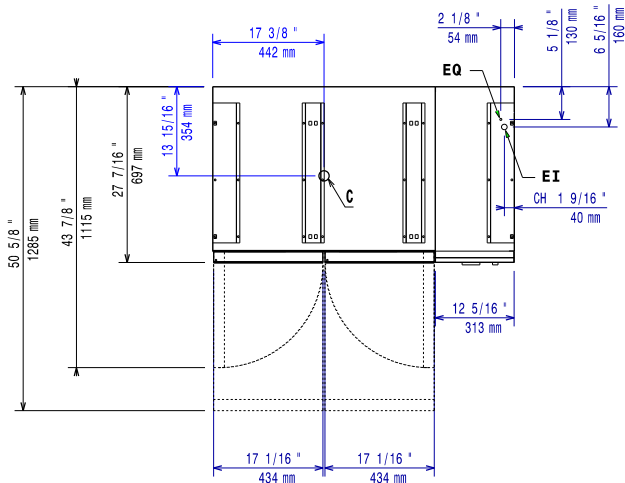

Electric

Supply voltage:	230 V/1N ph/50 Hz
Electrical power max.:	0.4 kW
Total Watts:	0.4 kW

Key Information:

External dimensions, Width:	1200 mm
External dimensions, Depth:	700 mm
External dimensions, Height:	600 mm
Net weight:	95 kg
Shipping weight:	114 kg
Shipping height:	820 mm
Shipping width:	800 mm
Shipping depth:	1300 mm
Shipping volume:	0.85 m ³
Gross capacity:	120 lt

Sustainability

Refrigerant type:	R290
Refrigerant weight:	85 g